

© 1964 BY AMP INCORPORATED. ALL RIGHTS RESERVED. AMP PRODUCTS COVERED BY PATENTS AND/OR PATENTS PENDING.

REVISIONS			
LTR	DESCRIPTION	DATE	APPROVED
A	REDRAWN & REVISED ECN P-5876 SK	2-17-69	RHW
B	REVISED B-630 WM	3-15-71	RY
C	REVISED ECN P-6932 T.R.	3-14-73	Qme
D	REVISED PER CG3A-0214-02	4/19/02	DR
E	REV PER ECR 05-006823 & 007199	7/21/05	DR/SM

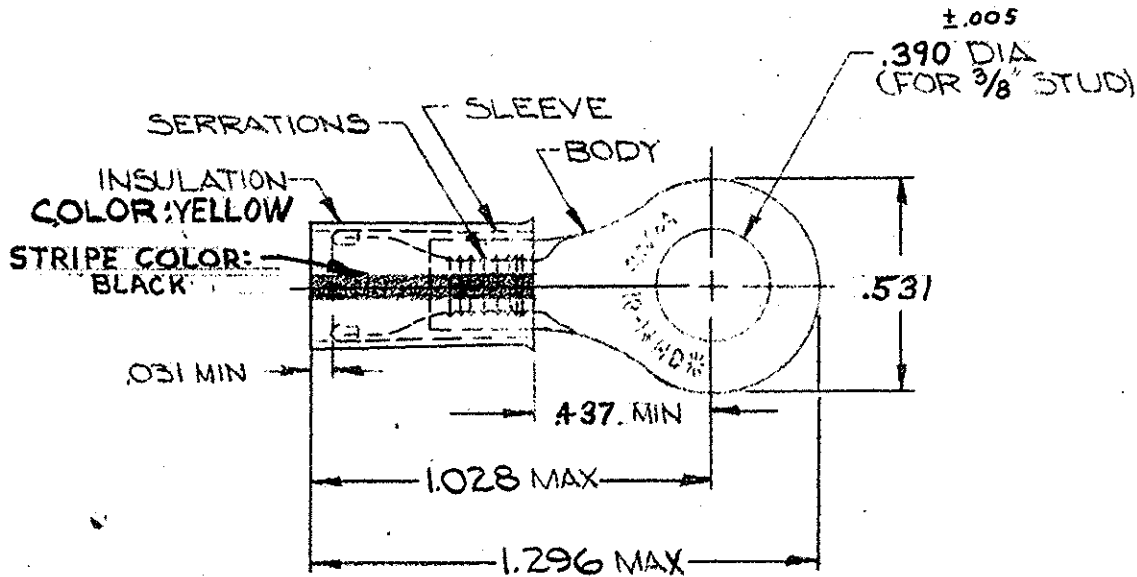

- 1 TONGUE MATERIAL THK = .048^{±.002}
- 2 FOR .150 TO .230 WIRE INSULATION DIA

2,500	WIRE TERMINAL ON TAPE	330896-2	SAME AS 330896
500	WIRE TERMINAL	330896	INSULATION: NYLON (MIL-M-20693) TYPE I. SLEEVE: COPPER (QQ-C-576) TIN PL (MIL-T-10727) BODY: COPPER (QQ-C-576) TIN PL (MIL-T-10727)
QTY	DESCRIPTION	PART NO.	MATERIAL & FINISH

UNLESS OTHERWISE SPECIFIED DIMENSIONS ARE IN INCHES TOLERANCES ON: DECIMALS ±.008 ANGLES ± 5°	CONTRACT NO. ---#---		AMP	AMP INCORPORATED HARRISBURG, PENNSYLVANIA	
	DR. <i>Stevens/Kant</i> 1-31-69			NAME	
	CHK. <i>R. Wolfe</i> 2-17-69		WIRE TERMINAL		
	APPD. <i>Swabel</i> 2-25-69		PIDG - RING TONGUE		
	REL. <i>Am Ensminger</i> 2/26/69		WIRE SIZE: 16-14 H.D.		
MATERIAL	DSGN APPD	SIZE	CODE IDENT NO.	NUMBER	
SEE TABLE		A	00779	330896	
	OTHER APPD	SCALE NTS		SHEET 1 OF 1	